

INCLINE DRAG CONVEYOR





High Performance and Efficiency from Every Angle

Setting the Standard

AGI's acquired line of handling equipment has been serving the Industry in very many ways since 1878. AGI incline drag conveyor systems continue the tradition of performance, efficiency and reliability over the long haul.

We take a sensible approach to systems design and construction, with a special attention to detail that matters.

It all starts with understanding every aspect of your operation including:

- Type of material you're handling
- Method of feeding the conveyor
- What your system requires in terms of volume and capacity
- Overall distance over which materials must travel

Then we engineer the system that makes the most sense for your application and budget.

You get an incline drag conveyor system that installs quickly and accurately. It is competitively priced and preforms flawless now and for years to come.

Efficiently Grain Handling

AGI drag conveyor systems are on the job in facilities around the world including:

- Commercial grain terminals and feed mills
- Port facilities
- Large farm operations with high capacity grain and livestock demands
- Small farm systems moving moderate volumes of grain

Preserving Grain Quality and Integrity

Grain-friendly AGI incline drag conveyors help preserve grain quality and integrity, especially when compared to screw conveyors which can severely damage grain.

With an AGI incline drag conveyor, you can reduce the depth of your boot pit and keep your elevators above ground for easier inspection and maintenance.

Wide range of capacities from 2,500 BPH (68 MTPH) to 20,000 BPH (544 MTPH) to meet your specific application and requirements.

AGI incline drag conveyors feature **galvanized (G-90) construction** for long life and reliable performance. Components that require welding are manufactured from mild steel with a powder coat finish.

Bolt-on flanges allow for easy adjustment and alignment.

Easily adaptable to your existing system to make retrofits and upgrades simple and affordable.

Reduced power consumption thanks to efficient design and performance — and that translates into bottom line savings.



AGI conveyor systems are perfect for transferring grain from a truck pit efficiently and quickly. AGI systems are easily adaptable to the most demanding installations, even in a "tight squeeze" configuration.

AGI Incline Drag Conveyors

Galvanized construction includes 11 GA (3 mm) intermediate sides with 8 GA (4.2 mm) bottom and 14 GA (2.0 mm) cover standard.

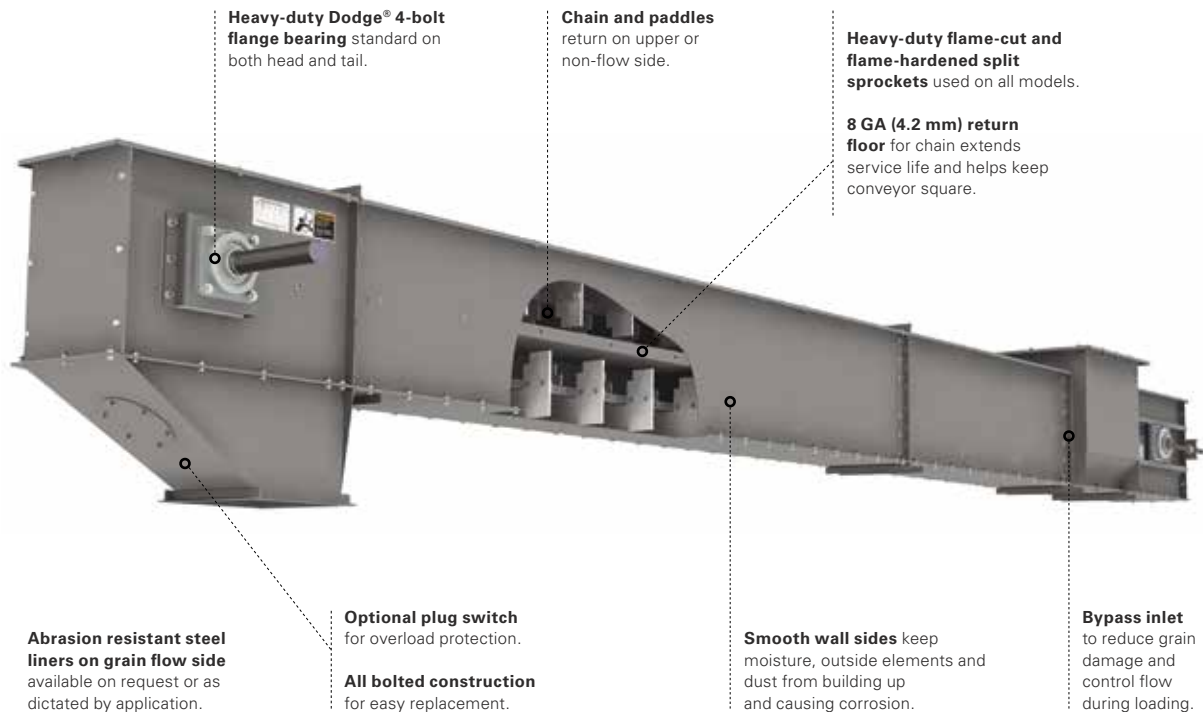

MODEL ID

These **“straight run” incline drag conveyors** are used to move material with maximum efficiency along set incline of up to 45°. AGI conveyors are commonly used for any application in which material must be conveyed along an incline of 10° or more.

AGI Model ID incline conveyors are used for:

- Distribution to overhead bins
- Carrying material up the incline of a structured grain bin roof
- Moving materials from below a truck receiving hopper up into a bucket elevator
- AGI Model ID systems can be designed to match your requirements for use from small farm systems to large commercial operations with capacities ranging up to 20,000 BPH (544 MTPH)
- A wide range of optional abrasive-resistant side and bottom liners are available for use in demanding commercial operations



Abrasion resistant (AR) bottom and side liners on grain flow side available on request.

81X and 81XHH roller chain used on models 1220, 1624 and 2124.
WH124 and WH132 used on models 2731 and 3336.

Curved elbows for inclines ranging from 5° to 45° on a 68" (1727 mm) radius.

MODEL IDC

These **“elbowed” incline conveyors** are engineered to move high volumes of material in specific configurations combining a horizontal distance with an incline ranging from 5° to 45° on a 68" (1727 mm) radius. An ideal application for the Model IDC is quickly moving high volumes of materials from an under-truck pit up into a bucket elevator.

Materials in the AGI Model IDC travel as a solid mass to eliminate turbulence—protecting material quality and integrity. These high-volume systems are designed and manufactured for strength, long life, and reliability.

AGI Model IDC systems can be designed for any use from small farm systems up to large commercial operations with capacities of 20,000 BPH (544 MTPH) and above. A wide range of optional abrasive-resistant side and bottom liners are available for use in demanding commercial operations.

Tail Sections

The tail sections on AGI incline drag conveyor systems are built to last. The bypass inlet diverts grain evenly and quickly around the paddles. Heavy-duty bearing and sturdy steel bottoms can handle tremendous volumes and weight.

All tail sections include a heavy-duty flame-cut and flame-hardened sprocket, with split sprockets are standard on all models. Specifications can be easily modified to match your application and capacity requirements.

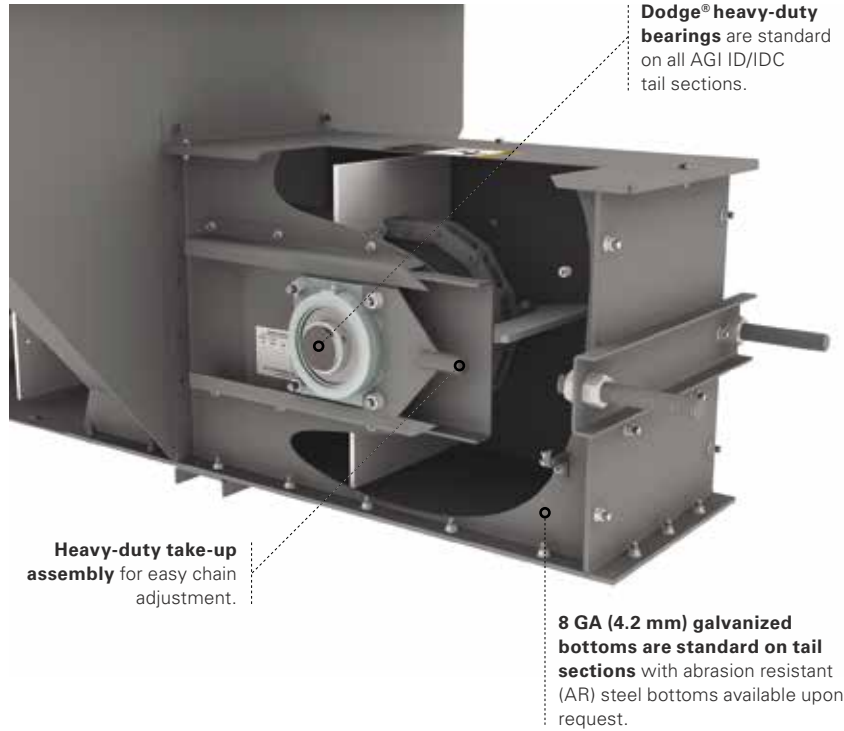

ADDITIONAL OPTIONS

Dump Hoppers



Drive-Over Grate Assembly

Rugged grates available for all conveyor sizes.



81X Chain



81XHH Chain



WH124 Chain

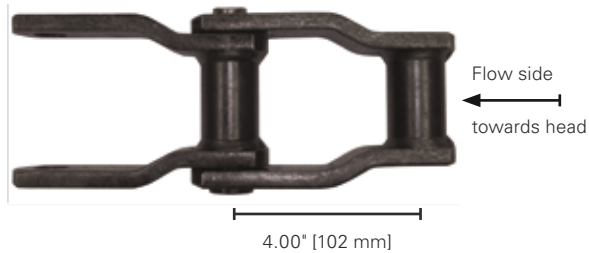

WH132 Chain

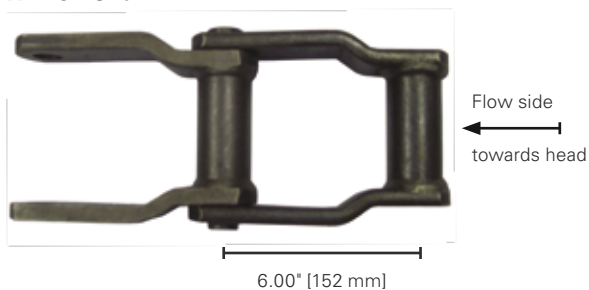

Chains, Sprockets & Paddles

Heavy-duty roller chain standard on all conveyors with flame-cut and flame-hardened sprockets. On systems of 15,000 BPH (381 MTPH) and above, split sprockets are standard on all conveyors.

IDC Backup Plates

Backup plates provide additional strength for paddles in moving large volumes of material.

- 3/8" (9.5 mm) UHMW paddles standard on all models
- 8 GA (4.2 mm) backup plates are standard on all ID16 and IDC16 conveyors and above.



Flame-cut and flame-hardened split sprockets standard

Details Make the Difference



Direct drive motorized torque arm (available on request) eliminates need for belt drive and belt guard. Unit is self-contained.



Plug switch option in head discharge eliminates potential overload concerns.

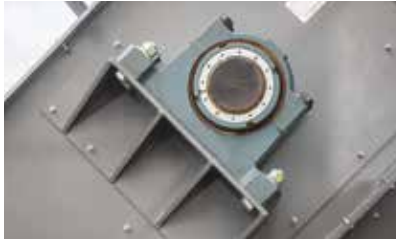

Heavy-duty gusset construction channels keep head and bearings rigid and stabilized during operation.



All Dodge speed reducers come furnished with a drive guard that **meets OSHA standards**.



AGI Model IDC conveyor system eliminates the need for a deep gravity pit and allows the elevator to be positioned above grade to avoid water damage.

MODEL	AH	AT	B	E	G	I*	J	K	L	M	N	P
ID & IDC 1220	31 7/8" [810 mm]	40" [1,016 mm]	24" [610 mm]	12" [305 mm]	20" [508 mm]	32" [813 mm]	12" [305 mm]	24" [610 mm]	12" [305 mm]	15 1/4" [387 mm]	20 1/2" [521 mm]	8 1/2" [216 mm]
ID & IDC 1624	37 7/8" [962 mm]	36" [914 mm]	24" [610 mm]	16" [406 mm]	24" [610 mm]	36" [914 mm]	16" [406 mm]	32" [813 mm]	16" [406 mm]	19 1/4" [489 mm]	28 1/4" [718 mm]	10" [254 mm]
ID & IDC 2124	37 7/8" [962 mm]	36" [914 mm]	24" [610 mm]	16" [406 mm]	24" [610 mm]	36" [914 mm]	21" [533 mm]	54" [1,372 mm]	21" [533 mm]	24 1/2" [616 mm]	48" [1,219 mm]	10" [254 mm]
ID & IDC 2731	50" [1,270 mm]	36" [914 mm]	24" [610 mm]	18" [457 mm]	31" [787 mm]	46 1/4" [1,175 mm]	26 3/4" [679 mm]	52" [1,321 mm]	27" [686 mm]	30" [762 mm]	48" [1,219 mm]	13 1/4" [337 mm]
ID & IDC 3336	62" [1,575 mm]	60" [1,524 mm]	77 3/4" [1,975 mm]	20" [508 mm]	37 3/4" [959 mm]	57" [1,448 mm]	33" [838 mm]	60" [1,524 mm]	33" [838 mm]	37 1/4" [946 mm]	54 3/8" [1,381 mm]	15 7/8" [403 mm]

DEGREE	MODEL ID 1220			MODEL ID 1624 & 2124			MODEL ID 2731			MODEL ID 3336		
	C	D	H	C	D	H	C	D	H	C	D	H
5	6" [152 mm]	1/4" [6 mm]	23" [584 mm]	6" [152 mm]	1/4" [6 mm]	28" [711 mm]	6" [152 mm]	1/4" [6 mm]	39" [991 mm]	8 1/2" [216 mm]	3/8" [10 mm]	50" [1,270 mm]
10	11 3/4" [298 mm]	1" [25 mm]	24" [610 mm]	11 3/4" [298 mm]	1" [25 mm]	27" [686 mm]	11 3/4" [298 mm]	1" [25 mm]	37" [940 mm]	16 3/4" [425 mm]	1 1/2" [38 mm]	48" [1,219 mm]
15	17 1/2" [445 mm]	2 1/4" [57 mm]	23" [584 mm]	17 1/2" [445 mm]	2 1/4" [57 mm]	25" [635 mm]	17 1/2" [445 mm]	2 1/4" [57 mm]	34 1/2" [876 mm]	24 3/4" [629 mm]	3 1/4" [83 mm]	45" [1,143 mm]
20	23 1/4" [591 mm]	4" [102 mm]	21" [533 mm]	23 1/4" [591 mm]	4" [102 mm]	24" [610 mm]	23 1/4" [591 mm]	4" [102 mm]	32" [813 mm]	32 3/4" [832 mm]	5 3/4" [146 mm]	42" [1,067 mm]
25	28 3/4" [730 mm]	6 1/2" [165 mm]	19" [483 mm]	28 3/4" [730 mm]	6 1/2" [165 mm]	21" [533 mm]	28 3/4" [730 mm]	6 1/2" [165 mm]	29" [737 mm]	40 1/2" [1,029 mm]	9" [229 mm]	38 3/4" [984 mm]
30	34" [864 mm]	9" [229 mm]	17" [432 mm]	34" [864 mm]	9" [229 mm]	19" [483 mm]	34" [864 mm]	9" [229 mm]	26" [660 mm]	48" [1,219 mm]	12 3/4" [324 mm]	35 1/4" [895 mm]
35	39" [991 mm]	12 1/4" [311 mm]	15" [381 mm]	39" [991 mm]	12 1/4" [311 mm]	17" [432 mm]	39" [991 mm]	12 1/4" [311 mm]	23" [584 mm]	55" [1,397 mm]	17 1/4" [438 mm]	31 1/2" [794 mm]
40	43 3/4" [1,111 mm]	16" [406 mm]	13" [330 mm]	43 3/4" [1,111 mm]	16" [406 mm]	14" [356 mm]	43 1/4" [1,099 mm]	16" [406 mm]	19 1/2" [495 mm]	61 3/4" [1,568 mm]	22 1/2" [572 mm]	27 1/2" [699 mm]
45	48" [1,219 mm]	20" [508 mm]	10" [254 mm]	48" [1,219 mm]	20" [508 mm]	12" [305 mm]	48" [1,219 mm]	20" [508 mm]	16" [406 mm]	68 3/8" [1,738 mm]	28 1/2" [724 mm]	23 1/4" [591 mm]

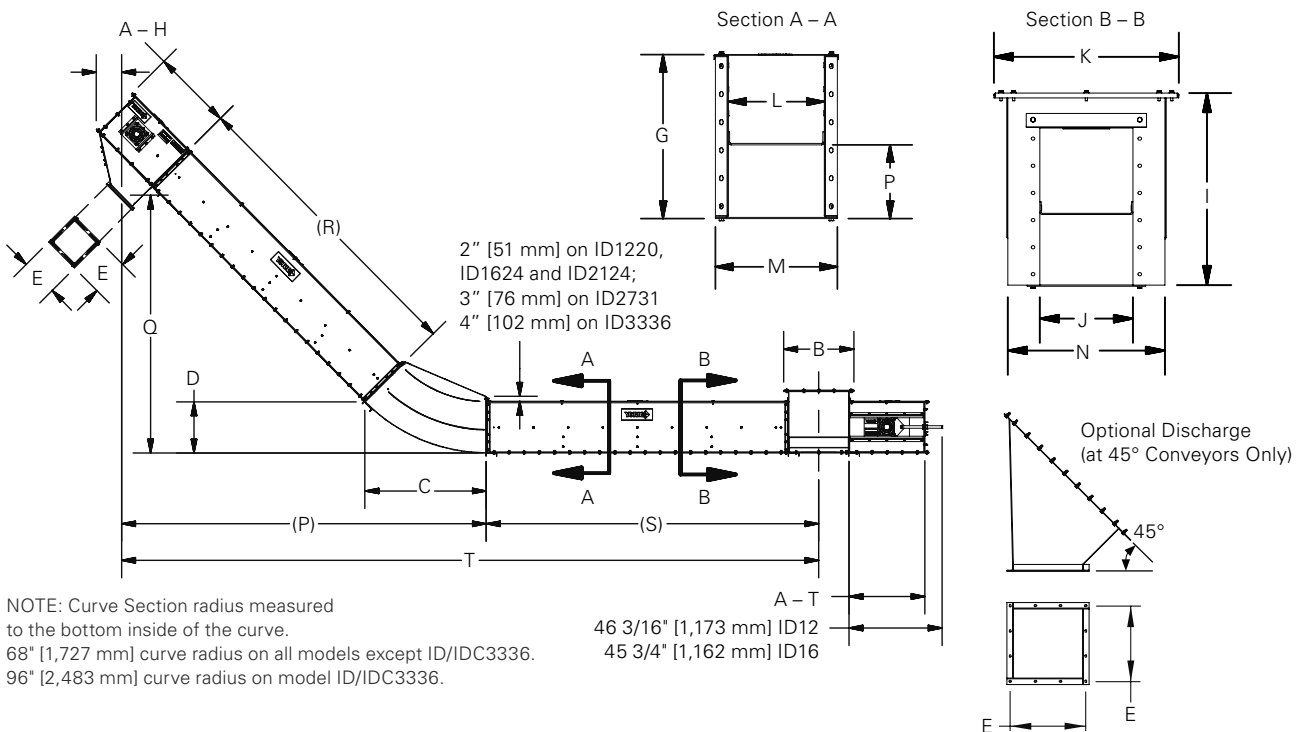

AGI INCLINE CONVEYOR CAPACITIES

BPH CAPACITY	MODEL	CUBIC FEET PER HOUR	CONVEYOR WIDTH	CONVEYOR HEIGHT	CHAIN SPEED	
					FT/MIN	RPM
2,500	ID/IDC1220	3,125	12"	20"	102	36
3,000	ID/IDC1220	3,750	12"	20"	122	43
3,500	ID/IDC1220	4,375	12"	20"	141	50
4,000	ID/IDC1220	5,000	12"	20"	161	57
4,500	ID/IDC1220	5,625	12"	20"	181	64
5,000	ID/IDC1220	6,250	12"	20"	201	71
5,000	ID/IDC1624	6,250	16"	24"	125	32
5,500	ID/IDC1624	6,875	16"	24"	141	36
6,000	ID/IDC1624	7,500	16"	24"	153	39
7,000	ID/IDC1624	8,750	16"	24"	176	45
7,500	ID/IDC1624	9,375	16"	24"	188	48
7,500	ID/IDC2124	9,375	21"	24"	145	37
8,000	ID/IDC2124	10,000	21"	24"	153	39
10,000	ID/IDC2124	12,500	21"	24"	192	49
10,000	ID/IDC2731	12,500	27"	31"	103	22
12,000	ID/IDC2731	15,000	27"	31"	121	26
15,000	ID/IDC2731	18,750	27"	31"	149	32
15,000	ID/IDC3336	18,750	33"	36"	95	21
20,000	ID/IDC3336	25,000	33"	36"	128	24

The above capacities are based on #2 Corn weighing 60 lbs./bushel.

INCLINE DRAG CONVEYOR SYSTEMS

- Industry-leading quality and innovation
- Wide range of models and capacities for virtually any application
- Easily adaptable to existing facilities and structures
- Competitive pricing without sacrificing quality
- Engineered for unmatched strength, Engineered for unmatched strength, long life, and outstanding performance outstanding performance
- Engineering expertise to help you match the right system to your requirements
- Complete grain handling systems including AGI bucket elevators and AGI en-masse conveyors

AGI INCLINE CONVEYOR CAPACITIES

MTPH CAPACITY	MODEL	CUBIC METERS PER HOUR	CONVEYOR WIDTH CM	CONVEYOR HEIGHT CM	CHAIN SPEED	
					M/S	RPM
68	ID/IDC1220	88.5	30.5	50.8	0.52	36
81	ID/IDC1220	106.2	30.5	50.8	0.62	43
95	ID/IDC1220	123.9	30.5	50.8	0.72	50
109	ID/IDC1220	141.6	30.5	50.8	0.82	57
124	ID/IDC1220	159.3	30.5	50.8	0.92	64
136	ID/IDC1220	177.0	30.5	50.8	1.02	71
136	ID/IDC1624	177.0	40.6	61.0	0.64	32
150	ID/IDC1624	194.7	40.6	61.0	0.72	36
163	ID/IDC1624	212.4	40.6	61.0	0.78	39
190	ID/IDC1624	247.8	40.6	61.0	0.90	45
204	ID/IDC1624	265.5	40.6	61.0	0.96	48
204	ID/IDC2124	265.5	53.3	61.0	0.74	37
218	ID/IDC2124	283.2	53.3	61.0	0.78	39
272	ID/IDC2124	354.0	53.3	61.0	0.98	49
272	ID/IDC2731	354.0	68.6	78.7	0.52	22
327	ID/IDC2731	424.8	68.6	78.7	0.62	26
408	ID/IDC2731	530.9	68.6	78.7	0.76	32
408	ID/IDC3336	530.9	83.8	91.4	0.48	21
544	ID/IDC3336	707.9	83.8	91.4	0.65	24

The above capacities are based on #2 Corn weighing 769kg/m³.





AGI is a leading provider of equipment solutions for agriculture bulk commodities including seed, fertilizer, grain, and feed systems with a growing platform in providing equipment and solutions for food processing facilities. AGI has manufacturing facilities in Canada, the United States, the United Kingdom, Brazil, India and Italy and distributes its products globally.



2928 East Highway 30, Grand Island, Nebraska, USA 68801
 1.800.247.6621 | sales@mfsyork.com

AGGROWTH.COM aggrowthintl